



Océ

VarioPrint®

6000 Ultra Line

Experience ultra speed



Ultra high speed digital perfecting systems

Ready to take your cutsheet printing performance to new heights? Meet the Océ VarioPrint® 6000 Ultra Line, the world's fastest and most productive family of digital perfecting printing systems. Choose from four models: the Océ VarioPrint 6320 Ultra, the Océ VarioPrint 6250 Ultra, the Océ VarioPrint 6200 Ultra and the Océ VarioPrint 6160 Ultra. And all are based on Océ Gemini Instant Duplex technology for unmatched power and scalability at speeds of 170, 200, 250 or a blazing 314 duplex images per minute.

General

- Océ Gemini Technology for instant duplex printing
- Advanced Active Registration technology
- Sophisticated media handling from up to 12 paper trays
- Paper Logic—for fast and easy paper orientation
- Intuitive 15" color touch screen user interface
- Increased throughput to handle more business
- Scalability and flexibility for protection of investment
- Handle the diverse challenges of book printing, transactional and reprographic jobs with a single solution

Technology

Printer type

- LED, 600 x 1200 dpi, 85/106/125/141/180 lpi

Engine technology

- Océ Gemini Technology for simultaneous duplex printing in a single pass

Production

Monthly duty cycle

- Océ VarioPrint 6320 Ultra: 1 million to 10 million prints
- Océ VarioPrint 6250 Ultra: 750,000 to 8 million prints
- Océ VarioPrint 6200 Ultra: 500,000 to 5 million prints
- Océ VarioPrint 6160 Ultra: 300,000 to 2.5 million prints

Print speed

- Océ VarioPrint 6320 Ultra: 314 A4/Letter prints per minute
168 A3/Ledger prints per minute
- Océ VarioPrint 6200 Ultra: 200 A4/Letter prints per minute
106 A3/Ledger prints per minute
- Océ VarioPrint 6250 Ultra: 250 A4/Letter prints per minute
132 A3/Ledger prints per minute
- Océ VarioPrint 6160 Ultra: 170 A4/Letter prints per minute
88 A3/Ledger prints per minute
- Print speed is independent of media type and weight.
- Easy temporary or permanent upgrade ability to higher speeds.

User interface

- Intuitive 15" color touch screen user interface
- Multiple views ensure a productive and controlled workflow
- Queue Manager, Job Scheduler, system status overview, multiple queues, job selection options, bundle printing

Paper Input Module

Functionality

- Maximum configuration - 3 paper input modules: 12 trays with a total capacity of 13,800 sheets
- Standard 4 trays, 4,600 sheets capacity.
- Paper tray capacity (80 g/m² plain paper)
 - 2 x 600 sheets
 - 2 x 1,700 sheets
- Sizes width: 203 - 320 mm (8"-12.6")
- Length: 203 - 488 mm (8"-19.2")
- All sizes between 203 x 203mm (8"x 8") and 320 x 488mm (12.6"x 19.2") (from all trays)

Paper weight

- From 60 - 200 g/m²
- From 50 - 300 g/m² on Océ approved media

Options

- 2nd and 3rd Paper Input Module
- Roll-feed, approximately 60,000 (80 g/m² plain paper) sheets
- Statement Size support 178 x 254 mm (7"x10")

High Capacity Stacker

Functionality

- Capacity 6,000 (2 stacks x 3,000) sheets - 80 g/m²
- All sizes between 203 x 203 mm (8"x 8") and 320 x 488 mm (12.6"x 19.2")
- Including tabs support
- OEM output to third-party finishing
- Maximum total stacking capacity 18,000 sheets (with 3 stackers attached)

Integrated Multi Format Stapler

Functionality

- Legal/ledger corner or dual stapling
- Mixed format stapling (50 sheets)
- Stapled output capacity: 2,000 sheets

Set Finisher (optional)

Capacity (80 g/m² plain paper)

4,000 sheets A4/Letter

Sizes

The following paper sizes can be stacked (and stapled) - all (custom) sizes between:

- long edge: 275-306 mm (10.8"-12")
- short edge: 208-220 mm (8.2"-8.7")
- Number of staples in a set: 1 or 2 position staple
- Stapling positions: portrait, landscape, book
- Stapling capacity: 100 sheets plain paper (80 g/m²)
- Shorter 50 sheet staple is available (optional)



Various configurations

In today's environment, people all have their own demands. That's why the Océ VarioPrint 6320, 6250, 6200 and 6160 Ultra are available in various configurations to fit perfectly with your individual needs and wishes. You can choose which combination of modules fits your needs. Available modules include:

- ❶ Paper Input Module(s)
- ❷ Océ Gemini Instant Duplex engine
- ❸ Océ High Capacity Stacker(s)
- ❹ Set finisher
- ❺ Integrated Multi Format Stapler (not pictured)

The integrated DFA interface allows these configurations to be further extended with various third-party finishing devices.

Finishing

Many online finishing options are available, including:

- Booklet making
- Perfect binding
- Document binding
- Punching

Connectivity

Supported PDLs

- PostScript 3 (standard)
- PDF
- PCL 6
- IPDS
- PCL_{5e}/PJL

Workflow support

- Automatic language sensing for PostScript, PDF and PCL 6
- Instant switching from IPDS or PCL_{5e}/PJL to PostScript 3/PDF/PCL 6
- Streaming behavior for all PDLs
- Xerox DigiPath[®] software and job ticket support with Océ DLink software
- Kodak SmartBoard[®] connectivity support with Océ KDKlink

Océ Applications support (optional)

- Océ PRISMA[®]access
- Océ PRISMAprepare
- Océ PRISMAproduction
- Océ PRISMA[®]satellite for ERP
- Océ Document Designer Advanced
- Océ PRISMA[®]pool
- Océ DPconvert
- Océ VPconvert

Network hardware

- 10/100 Mb, 1Gb Ethernet Network protocols
- TCP/IP
- Novell (IPX/SPX)
- SMB

Higher-level protocols

- LPR/LPD for print job submission
- Socket printing
- SNMP
 - Host Resources
 - MIBII
 - Printer MIB
 - Job Monitoring MIB

Physical data

Sound Power

- Standby 58 dB
- Running 78 dB

Power consumption stand-by

1 kW

Power consumption in running mode

- Océ VarioPrint 6160 4.0 kw
- Océ VarioPrint 6200 4.3 kw
- Océ VarioPrint 6250 4.4 kw
- Océ VarioPrint 6320 4.9 kw

Sizes and Weights:				
	Weight Kg	Length mm	Width mm	Heights mm
Print Engine (PE)	680	1443	1070	1204
Paper Input Module (PIM)	230	992	718	1150
Input Interface Module (IIM)	102	485	720	1140
High Capacity Stacker including finisher (HCS/FIN)	290	1154	716	1928
High Capacity Stacker (HCS)	160	1154	716	1169

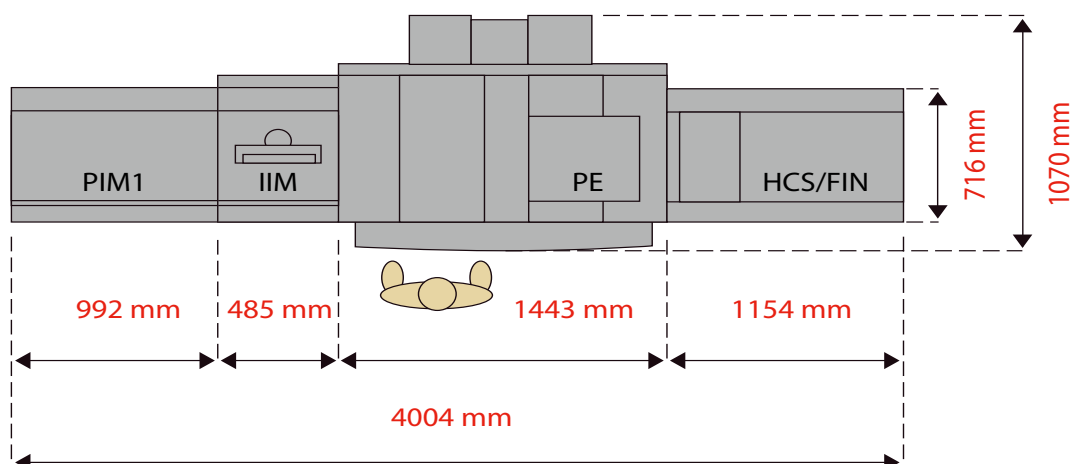

Beyond the Ordinary



Printing for Professionals

Océ VarioPrint 6000 Technology and Awards*



Golden Medal 2007,
Poznań International Fair
(Europe)

Best Product 2007

Best product of the Year
2007, European Digital Press
Association (Europe)



Best of Show Award
2006, On Demand
(USA)



InterTech Technology Award
2007, Printing Industries of
America/Graphic Arts Technical
Foundation (USA)

*Awarded 2008, 2007, 2006

Océ helps the people who make our world. Companies everywhere use Océ technical documentation systems in manufacturing, architecture, engineering and construction. Each week, high speed Océ printing systems produce millions of transaction documents such as bank statements and utility bills. And in offices around the world, people use Océ professional document systems to keep the wheels of business and government turning. Océ is also at work in publishing on demand, newspaper production, document management outsourcing and wide format colour for spectacular display graphics. It all helps our professional customers go 'Beyond the Ordinary' in printing and document management.

©2009 Océ. Illustrations and specifications do not necessarily apply to products and services offered in each local market. Technical specifications are subject to change without prior notice. Océ, and Océ VarioPrint® and Océ PRISMA® are registered trademarks of Océ-Technologies B.V.. Xerox DigiPath® and Kodak SmartBoard® are registered trademarks of the Xerox and Kodak companies. All other trademarks are the property of their respective owners.

For information and services, visit us at:

www.océ.com